

**Davies Remanufactured**  
**Herman Miller A02**



**DISASSEMBLY INSTRUCTIONS**



# Remanufactured Herman Miller AO2

## DISASSEMBLY INSTRUCTIONS

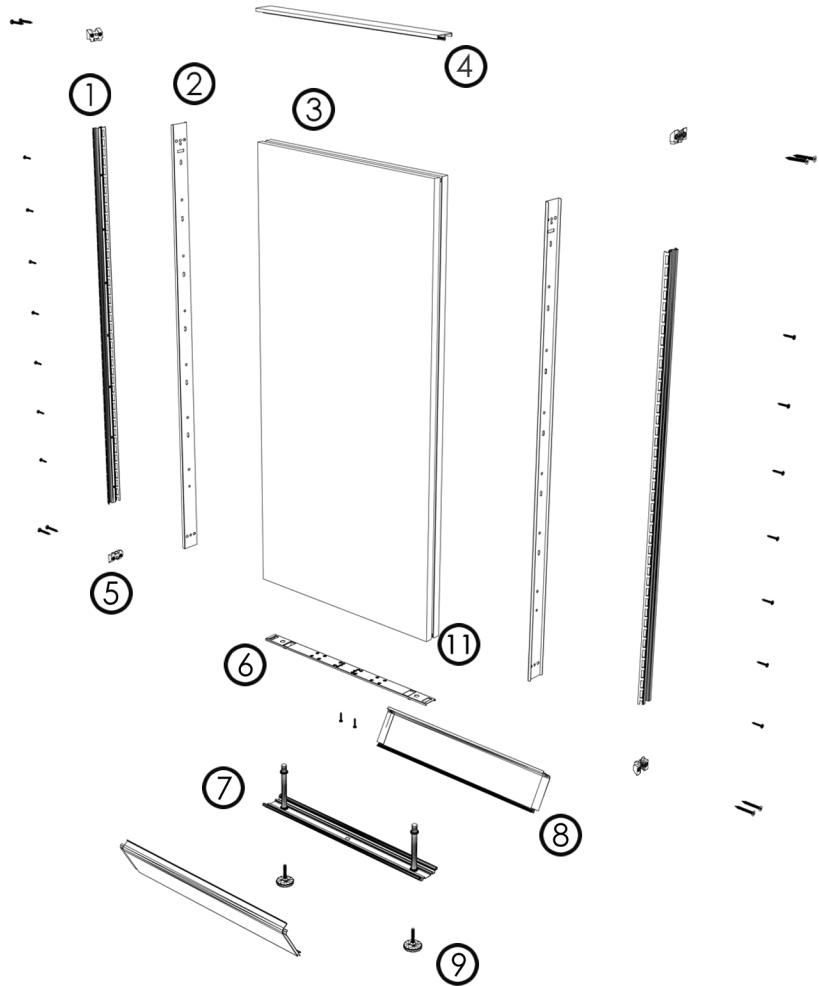

- ① Mounting Track (steel) x2 ♻️
- ② Side Rail (steel) x2 ♻️
- ③ Panel Core (mdf/pressboard)
- ④ Top-Cap (abs plastic)
- ⑤ Mounting Block (steel) x4 ♻️
- ⑥ Bottom Rail (steel) ♻️
- ⑦ Base Plate / Legs (steel) ♻️
- ⑧ Kick-Plates (vinyl)
- ⑨ Glides (abs plastic / steel)
- ⑩ Hardware (steel) ♻️
- ⑪ Acoustic Batting (fiberglass)

♻️ Items that should be recycled if they cannot be re-used or remanufactured. For more information on where to recycle materials or other recovery options, please review the Davies End of Life Recycling infrastructure Matrix and Davies End of Life Recovery Options Matrix.

Available online at: <http://daviesoffice.com/environment/>



**WHAT LEGENDS ARE RE-MADE OF**

# Remanufactured HM A02

## DISASSEMBLY INSTRUCTIONS

### STANDARD TOOLS REQUIRED

---



Standard Flat-Head Screwdriver



Standard #2 Phillips Head Screwdriver

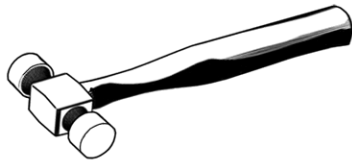

Hammer or Mallet

**DAVIES**  
office refurbishing, inc. 

**WHAT LEGENDS ARE RE-MADE OF**

# Herman Miller AO2

## DISASSEMBLY INSTRUCTIONS

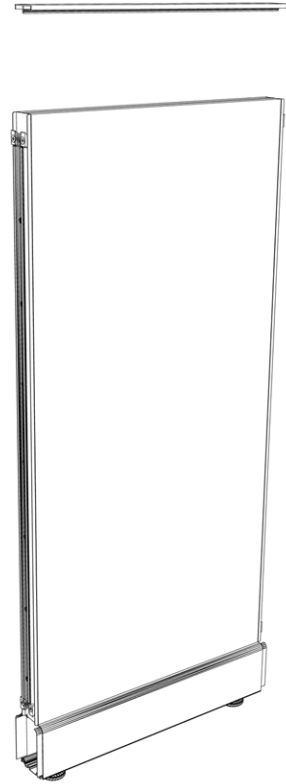
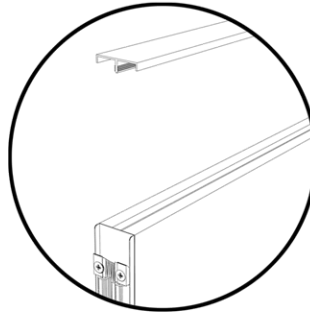

### STEP 1

Begin by removing the top-cap. This can be done by simply pulling up upward with your hands.

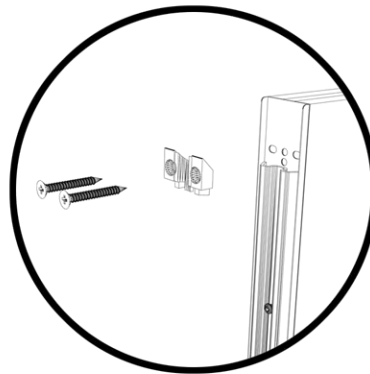
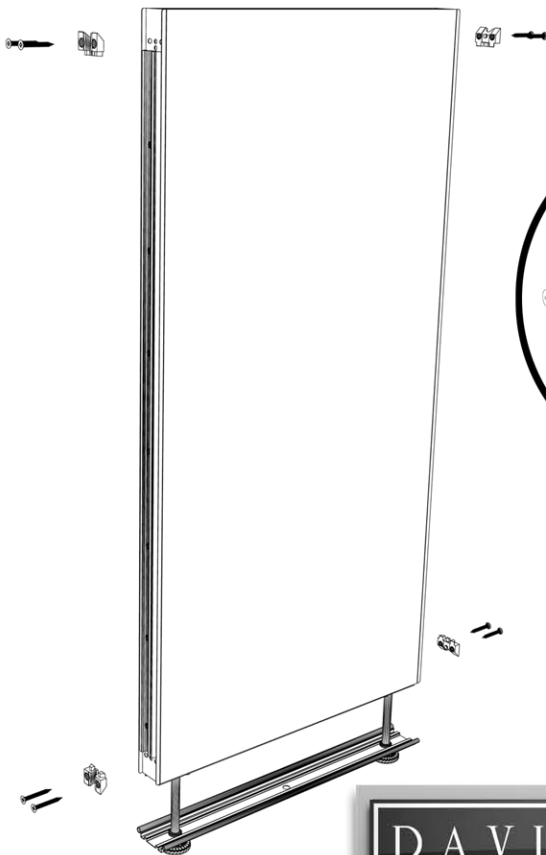

### STEP 2

Using a philips-head screwdriver, remove the screws holding the connecting blocks.

**DAVIES**  
office refurbishing, inc.



WHAT LEGENDS ARE RE-MADE OF



# Herman Miller AO2

## DISASSEMBLY INSTRUCTIONS

### STEP 3

Now, remove all of the screws from the side rails, with a philips-head screwdriver. Once you've removed the screws, the mounting tracks and side rails will be free.

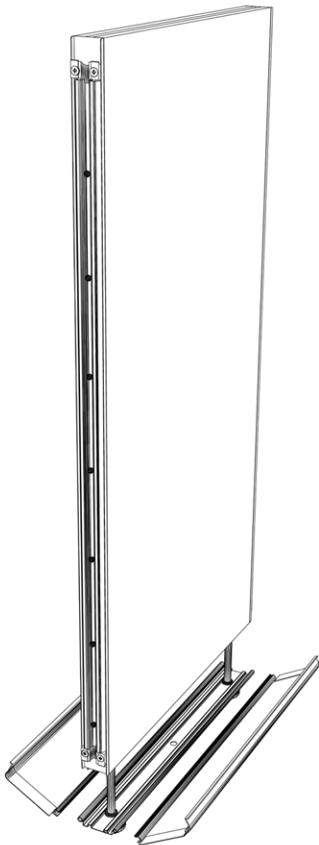
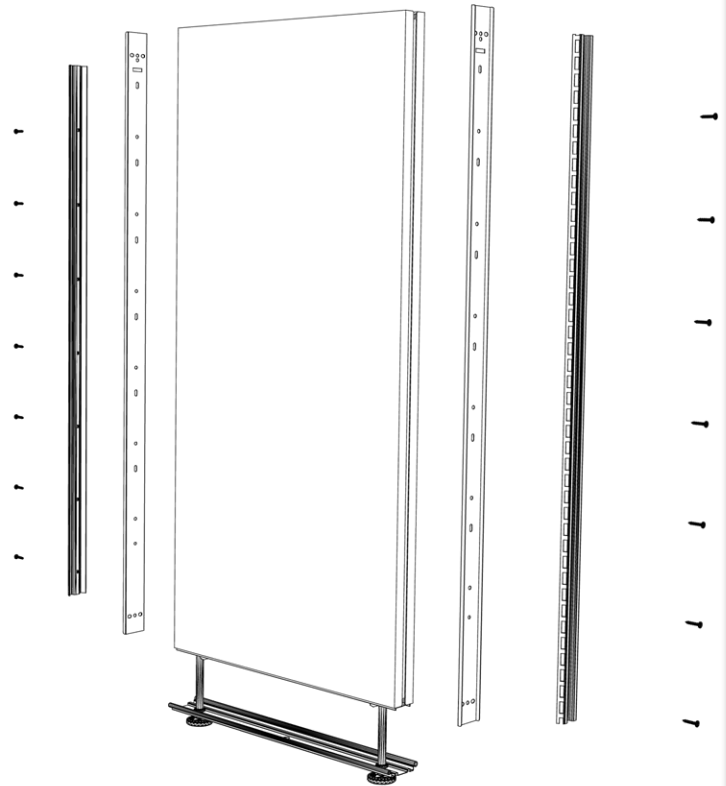

### STEP 4

Remove kickplates. Push down on the top of the kickplates and pull them out toward you. They pivot on the panel base plate. Once you pivot them out, pull them toward you and they'll pop off of the base plate.

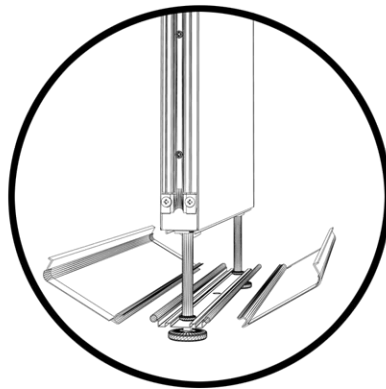

**DAVIES**  
office refurbishing, inc.



WHAT LEGENDS ARE RE-MADE OF

# Herman Miller AO2

## DISASSEMBLY INSTRUCTIONS

### STEP 5



Lay the panel down. Use a wooden or rubber mallet to tap the base away from the panel core. Keep tapping until the leg posts are free of the panel.

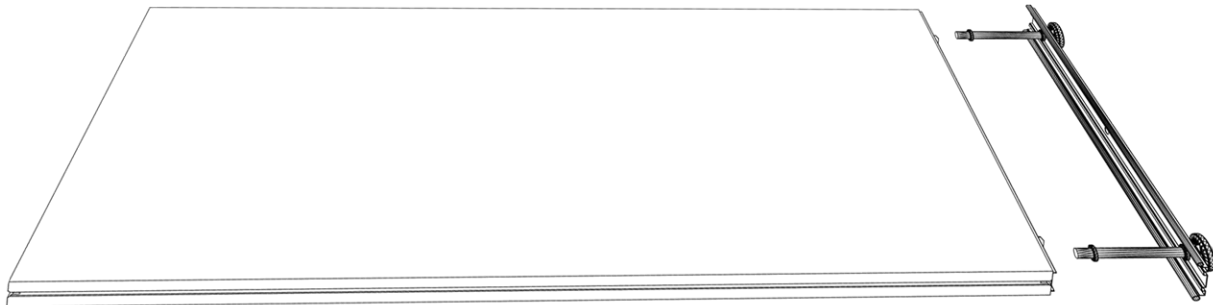

### OPTIONAL STEP

The height adjustment glides can be removed from the base, if necessary. They can be removed by unscrewing them from the legs, by hand.

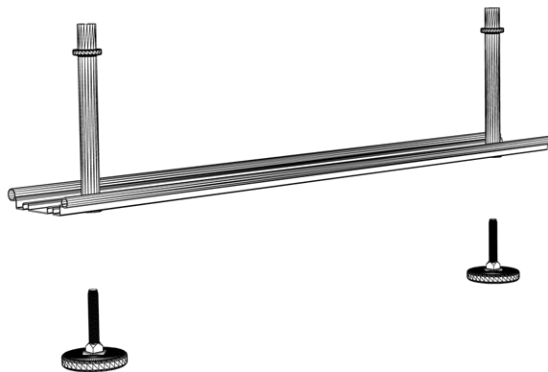

**DAVIES**  
office refurbishing, inc.



WHAT LEGENDS ARE RE-MADE OF

# Herman Miller AO2

## DISASSEMBLY INSTRUCTIONS

### STEP 6

Use your philips-head screwdriver to remove the (2) remaining screws on the panel. Once these screws have been removed the base track can also be removed.

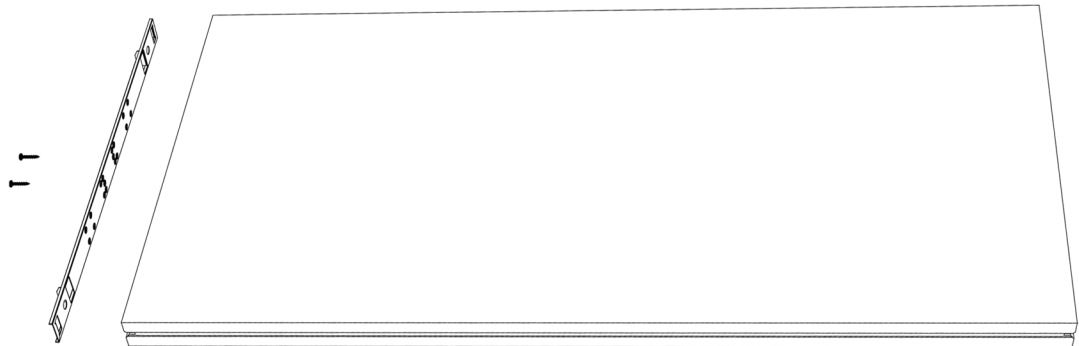

### STEP 7

All that's left to do is removing the fabric skin. The fabric is stapled to the panel core. Use a flat-head screwdriver to remove the staples and then peel the fabric off.

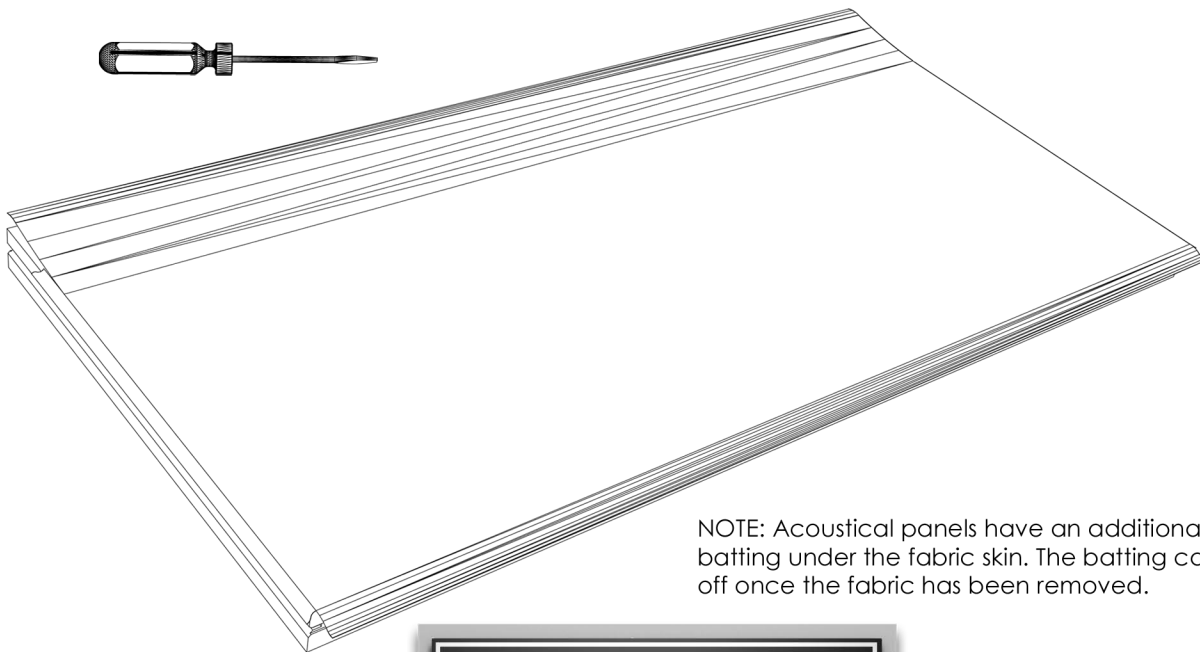

NOTE: Acoustical panels have an additional acoustic batting under the fabric skin. The batting can be lifted off once the fabric has been removed.

**DAVIES**  
office refurbishing, inc. 

**WHAT LEGENDS ARE RE-MADE OF**